

ICC-ES Evaluation Report

ESR-1129

Reissued June 1, 2009

This report is subject to re-examination in two years.

www.icc-es.org | (800) 423-6587 | (562) 699-0543

A Subsidiary of the International Code Council®

DIVISION: 07—THERMAL AND MOISTURE PROTECTION
Section: 07310—Shingles

REPORT HOLDER:

TAMKO BUILDING PRODUCTS, INC.
POST OFFICE BOX 1404
JOPLIN, MISSOURI 64802
(417) 624-6644
www.tamko.com

EVALUATION SUBJECT:

**METALWORKS STEEL ROOFING SHINGLES:
ASTONWOOD, STONECREST SLATE AND STONECREST
TILE**

1.0 EVALUATION SCOPE

Compliance with the following codes:

- 2006 *International Building Code*® (IBC)
- 2006 *International Residential Code*® (IRC)
- 1997 *Uniform Building Code*™ (UBC)

Properties evaluated:

- Roof covering fire classification
- Wind uplift resistance
- Weather resistance

2.0 USES

The MetalWorks Steel Roofing Shingles (AstonWood, StoneCrest Slate and StoneCrest Tile) covered in this report comply with IBC Section 1507.5, IRC Section R905.4 and UBC Section 1507.8. The shingles are recognized as Class A or Class C roof covering assemblies on new or existing roofs, when installed in accordance with this report.

3.0 DESCRIPTION

3.1 General:

The MetalWorks AstonWood, StoneCrest Slate and StoneCrest Tile metal shingles are pressure-formed from nominally 0.0135-inch-thick (0.34 mm) sheet steel complying with ASTM A 653, Grade CS, Type B, having a G90 galvanized coating complying with ASTM A 90. The exterior face is coated with an anticorrosive primer plus a polymer top coat. The interior is coated with an anticorrosive primer plus a wash coat. The shingles are formed by an automated multistage die and have factory-formed interlocking edges at the perimeter. See Figure 1 for additional details.

3.2 AstonWood Shingles:

The AstonWood shingles are nominally 12⁵/₈ inches (321 mm) long by 39³/₄ inches (1010 mm) wide, and are textured to resemble wood shakes. Each shingle has a nominal weight of 2 pounds (0.9 kg), and an installed weight of 0.61 pound per square foot (2.98 kg/m²).

3.3 StoneCrest Slate and StoneCrest Tile Shingles:

The StoneCrest shingles are nominally 12⁵/₈ inches (321 mm) long by 39³/₄ inches (1010 mm) wide. The StoneCrest Slate shingles are textured to resemble slate and the StoneCrest Tile shingles are textured to resemble tile. Each shingle has a nominal weight of 2.5 pounds (1.13 kg) and an installed weight of 0.74 pound per square foot (3.61 kg/m²).

3.4 Accessories:

Accessories are formed from the same material and include ridge/hip cap, starter/eave flashing, J-channel, sidewall flashing, gable/rake flashing, and valley flashing. See Figure 2 for additional details.

3.5 Nailing Clips:

Nailing clips used to fasten the shingles to the sheathing are formed from G90 galvanized 0.015-inch-thick (0.4 mm) steel. See Figure 1 for additional details.

3.6 Fasteners:

Fasteners used with the nailing clips to attach the shingles and flashing to the sheathing shall be minimum No. 11 gage [.0120-inch-diameter shank (3.05 mm)], smooth or ring-shank, galvanized roofing nails having a minimum ³/₈-inch (9.5 mm) head diameter. Fasteners shall be long enough to penetrate ³/₄ inch (19 mm) into or through the thickness of the plywood sheathing.

3.7 Underlayment:

Underlayment must comply with ASTM D 226, Type II (IBC or IRC) or Type 30 (UBC), asphalt-saturated felt, or must be TAMKO's TW Metal and Tile Underlayment ([ESR-2531](#)) or TAMKO's TW Underlayment ([ESR-1252](#)).

4.0 INSTALLATION

4.1 Roof Slope:

The shingles are installed on minimum roof slopes of 3:12 (25% slope).

4.2 Installation—New Construction Class C:

The MetalWorks shingles are installed in accordance with the manufacturer's published installation instructions. The shingles are installed over code-complying, minimum ¹⁵/₃₂-inch-thick (11.9 mm) plywood sheathing installed in accordance with the applicable code. A full-width layer of

Type II (Type 30) underlayment is installed over the sheathing at the eaves, along the roof perimeter. The eave/starter flashing is installed over the underlayment using 1¹/₂-inch-long (38 mm), galvanized roofing nails spaced 36 inches (915 mm) on center. A second layer of Type II (Type 30) underlayment is installed over the eave/starter flashing and continued up the roof with overlaps of 2 inches (51 mm) horizontally and 4 inches (102 mm) vertically, and is fastened with 7/8-inch-long (22 mm), corrosion-resistant roofing nails spaced 12 inches (305 mm) on center on the overlaps and in the field. Gable and rake flashing is installed over the underlayment using 1¹/₂-inch-long (38 mm), galvanized roofing nails spaced 36 inches (914 mm) on center. The first row of shingles is started at the lower-left eave and interlocks with the eave flashing. Subsequent courses are installed similarly, with staggered patterns as shown in Figure 3. Shingles are attached to the deck using a minimum of three nailing clips per full-width shingle, equally spaced from each end. The nailing clips are fastened to the deck using fasteners described in Section 3.6. See Figure 4 for typical installation details.

Valleys are flashed with TAMKO TW Metal and Tile Underlayment or TW Underlayment, beneath the metal valley flashing, in addition to the underlayment required for the field of the roof. The metal valley flashing is fastened to the deck using nailing clips on each side of the flashing, spaced 36 inches (915 mm) on center. Shingles are cut to fit into the valley flashing. Hip and ridge pieces are installed in accordance with the manufacturer's installation instructions.

4.3 Installation—New Construction Class A:

Installation is as noted in Section 4.2 except that a barrier consisting of minimum 1/4-inch-thick (6.4 mm) Georgia Pacific Dens Deck® overlayment board or 1/2-inch-thick (12.7 mm) gypsum sheathing is installed, over the plywood sheathing, with all joints staggered a minimum of 6 inches (152 mm), both horizontally and vertically, from the plywood joints. The Georgia Pacific Dens-Deck® or gypsum sheathing is attached with a minimum of six roofing nails per 4-foot-by-8-foot (1219 mm by 2438 mm) sheet, and is installed over the plywood sheathing and under the underlayment. Fasteners used to attach the shingles and the barrier board must be as described in Section 3.6.

4.4 Severe Climate Areas:

In areas subject to wind-driven snow, ice buildup, or wind-driven dust or sand, or in other areas designated by the code official, both of the following conditions shall apply:

Solid sheathing with two layers of ASTM D 226, Type I (IBC and IRC) or Type 15 (UBC) felt for the field of the roof.

Solid sheathing with two layers of ASTM D 226, Type I (IBC and IRC) or Type 15 (UBC) felt applied shingle-fashion and solid-cemented together with approved cementing material between the plies, extending from the eave up the roof to a point 24 inches (610 mm) inside the exterior wall line of the building under the IBC and the IRC, and 36 inches (914 mm) under the UBC. TAMKO TW Metal and Tile Underlayment or TW Underlayment may be used in lieu of two layers of Type I or Type 15 underlayment solid-cemented together over the eave area noted above.

4.5 Wind Resistance:

4.5.1 IBC and IRC: When installed in accordance with this report, the MetalWorks shingles are limited to installation in Exposure B areas where the maximum basic

wind speed is 100 mph (161 km/h) (3-second gust) on structures with a maximum roof height of 40 feet (12 192 mm) or less.

4.5.2 UBC: When installed in accordance with this report, the MetalWorks shingles are limited to Exposure B areas subjected to a maximum basic wind speed (fastest mile) of 80 mph (129 km/h) on structures having a mean roof height of 40 feet (12 192 mm) or less.

4.6 Reroofing Installation:

4.6.1 General: If the existing roof covering is completely removed, installation must be in accordance with Sections 4.1 through 4.4 of this report.

For the shingles to be installed over existing roofing materials without removal of the existing roof covering, installation must be in accordance with Section 1510 of the IBC, Section R907 of the IRC or Appendix 15 of the UBC. Prior to installation of the new roof covering, the existing hip and ridge materials must be removed and the roof cleaned of any loose gravel or debris.

4.6.2 Reroofing Classification:

4.6.2.1 Class A: When the Class A assembly described in Section 4.3 of this report is installed over an existing Class A, B, or C roof covering, the existing roof covering classification remains unchanged.

4.6.2.2 Class C: When the Class C assembly described in Section 4.2 of this report is installed over an existing Class A, B, or C roof covering that is installed over minimum 15/32-inch-thick (11.9 mm) plywood sheathing, the new roof is a Class C.

4.6.2.3 Installation over Wood Shakes or Shingles: MetalWorks shingles installed over existing wood shingles or shakes is limited to buildings permitted by the applicable code to have nonclassified or nonrated roofing.

5.0 CONDITIONS OF USE

The MetalWorks Steel Roofing Shingles described in this report comply with, or are suitable alternatives to what is specified in, those codes listed in Section 1.0 of this report, subject to the following conditions:

5.1 Products are identified and installed in accordance with this report and the manufacturer's published installation instructions. If there is a conflict between the manufacturer's installation instructions and this report, this report shall govern.

5.2 Only Metalworks steel roof shingle accessories and specified fasteners shall be used in the installation of the roof covering system.

5.3 MetalWorks steel shingles are manufactured in Joplin, Missouri, under a quality control program with inspections by Underwriters Laboratories Inc. (AA-668).

6.0 EVIDENCE SUBMITTED

Data in accordance with the ICC-ES Acceptance Criteria for Metal Roof Coverings (AC166), dated February 2007.

7.0 IDENTIFICATION

Each package of MetalWorks steel roofing shingles shall be labeled with the report holder's name (TAMKO Building Products, Inc.) and address, the product name, the evaluation report number (ESR-1129) and the name of the inspection agency.

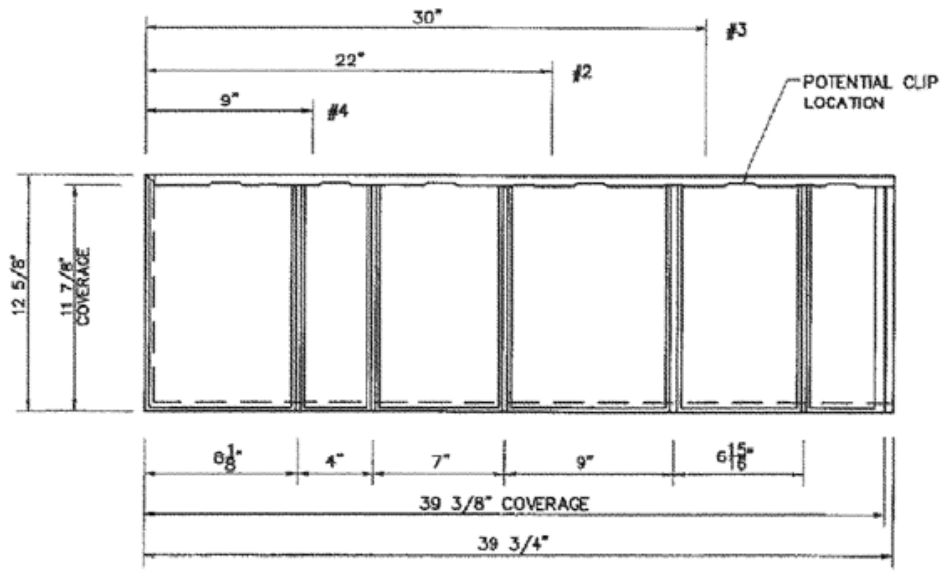

AstonWood

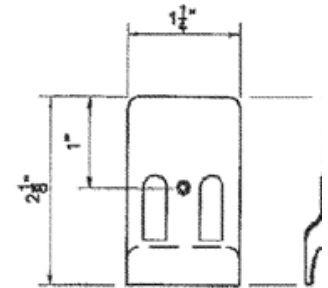

NAILING CLIP

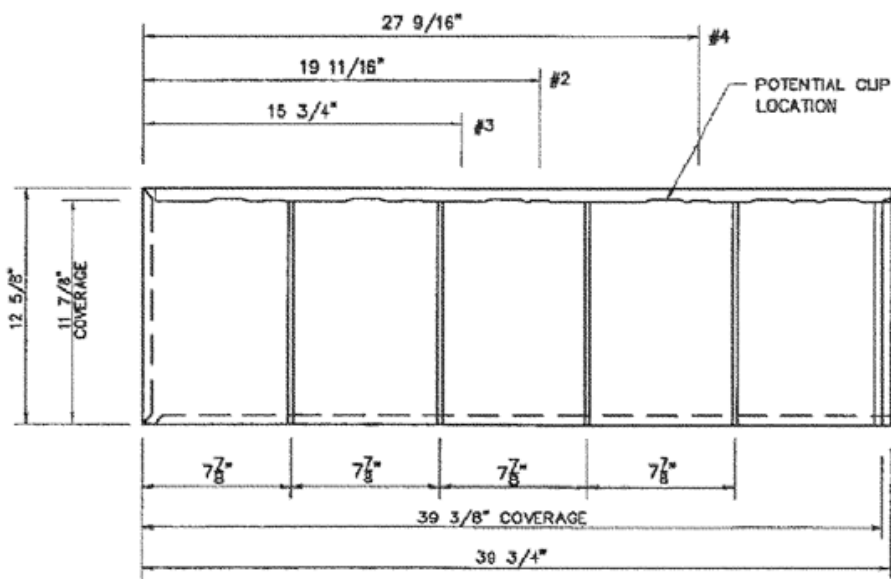

StoneCrest

FIGURE 1—PANEL/CLIP DETAIL

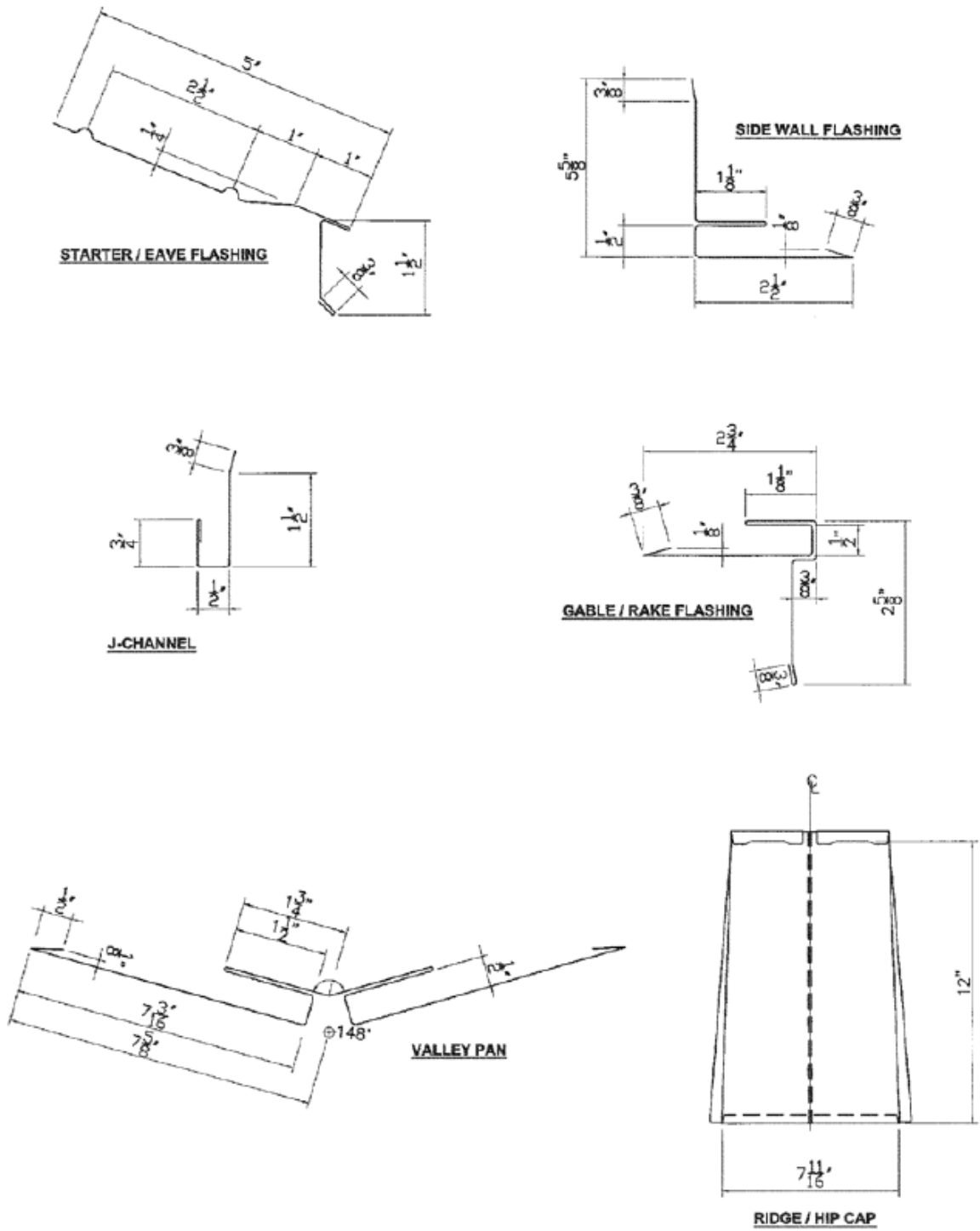

FIGURE 2—TRIM AND FLASHING DETAILS

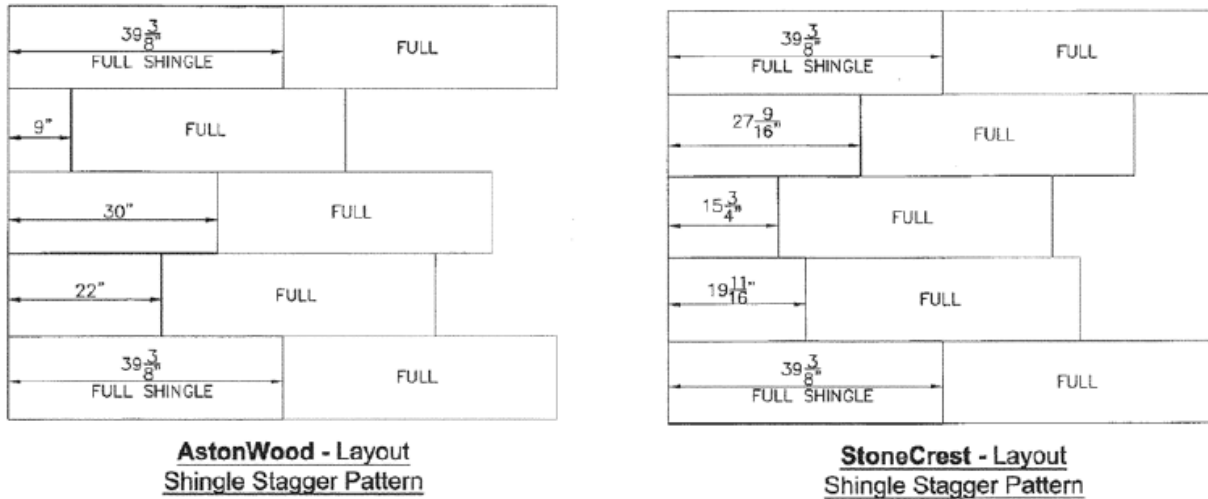

FIGURE 3—LAYOUT PATTERNS

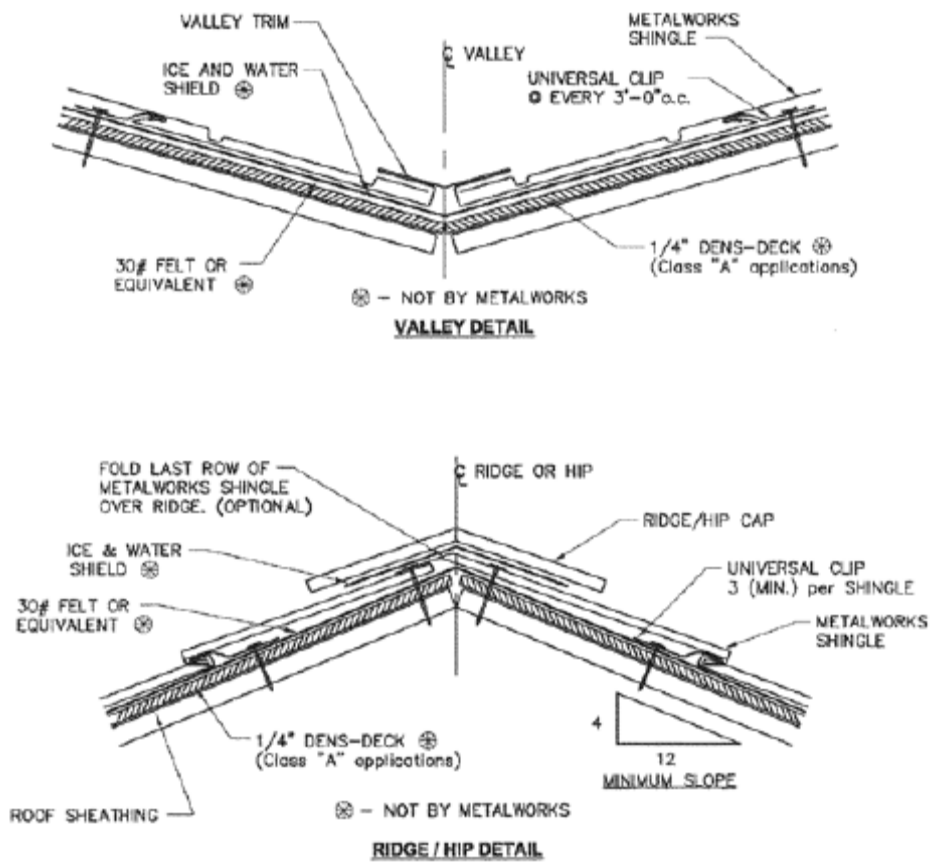
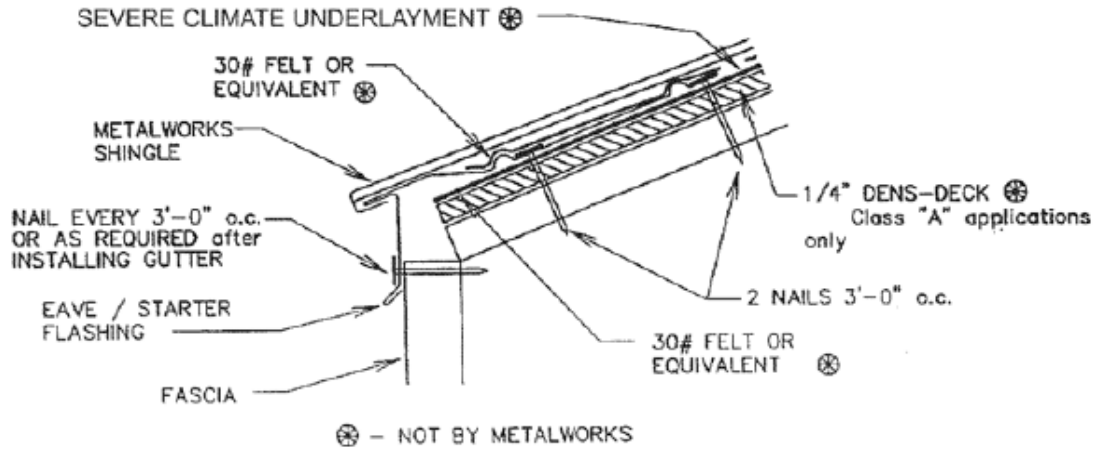
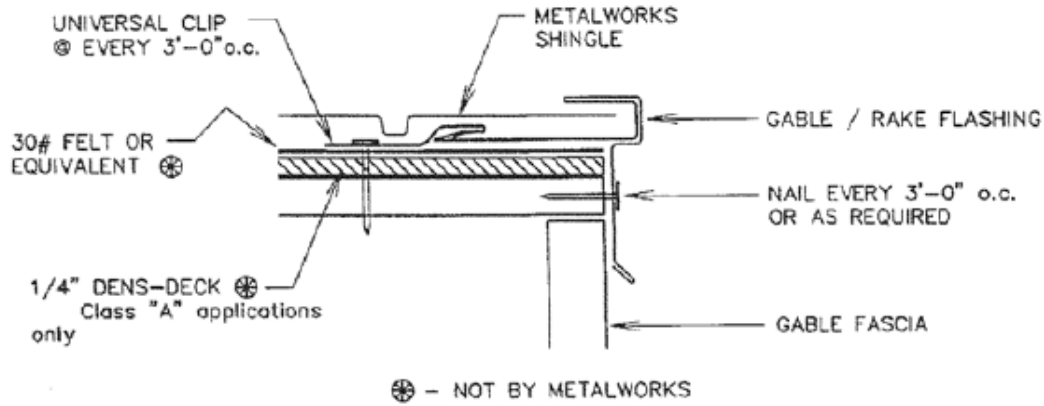

FIGURE 4—TYPICAL INSTALLATION DETAILS



STARTER / EAVE DETAIL



GABLE / RAKE DETAIL

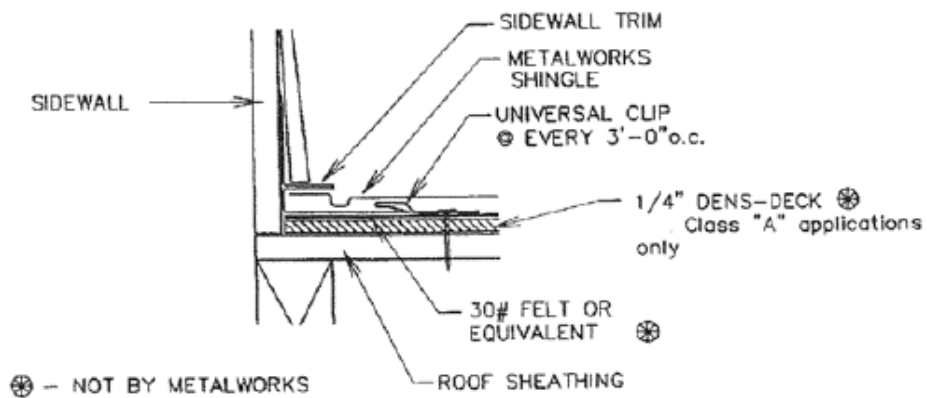

SIDEWALL / DORMER / SKYLIGHT / CHIMNEY DETAIL

FIGURE 4—TYPICAL INSTALLATION DETAILS (Continued)